

# SBC6511

## Rugged SOSA Aligned 6U VPX Single Board Computer with 9<sup>th</sup> Gen Intel Xeon E CPU

The SBC6511 Rugged Single Board Computer (SBC) from Abaco Systems features the new high performance, highly integrated Intel® Xeon® E processor ('Coffee Lake Refresh').

### High Performance, High Reliability

The new Xeon E combines six 9th Generation Core™ i7 technology processing cores with a rich I/O mix, all with the backing of Intel's Embedded Use Conditions – ideal for long term, high reliability applications.

The SBC6511 offers memory resources including 64 GB of high speed DDR4 SDRAM and up to 256 GB NAND Flash (NVMe SSD), plus a range of I/O including DisplayPort™, USB, GPIO and serial comms. Two on-board mezzanine expansion sites are also provided for enhanced system flexibility.

In alignment with the SOSA™ technical standards and in support of the DOD's C4ISR/ EW Modular Open Suite of Standards (CMOSS), the SBC6511's data plane fabric connectivity is via 40G capable Ethernet fat pipes, with a Gen 3 capable PCIe™ quad fat pipe providing the expansion plane. Control plane connectivity on

the backplane is via two 10G capable Ethernet ultra-thin pipes and two 1000BASE-T thin pipes for external connection.

Available in a range of air- and conduction cooled build levels with extended temperature capability, the SBC6511 is designed to meet the requirements of a wide range of applications from industrial through to fully rugged defense and aerospace programs.

It is especially adept at applications requiring heavy throughput and extensive I/O processing, like radar and SIGINT applications.

### Enhanced Security Features

The SBC6511 incorporates a range of security features designed to assist with user defined Anti-Tamper and Information Assurance strategies. These include an inherently secure FPGA solution (Xilinx® Zynq® UltraScale+™), and support for Intel's Trusted Execution Technology. The FPGA can be utilized to instantiate a range of Abaco-defined security features, or by the customer to embed application specific features.

### FEATURES:

- Xilinx Zynq Ultrascale+
- 6U OpenVPX single board computer
- 9th Generation Intel® Core™ i7
- 12 MB shared cache
- Soldered DDR4 SDRAM with ECC
- Up to 256 GB solid state disk drive
- Multiple Data Plane Fabric Configurations (10/40GE)
- Multiple PCIe® Expansion Plane Fabric configurations
- Both rear & front I/O ports
- On-board expansion sites
- Trusted Platform Monitor (TPM)
- Elapsed Time Indicator (ETI)
- Rich software choice, including Deployed Test Software, plus operating systems support for Microsoft® Windows, Open Linux® and VxWorks®
- Middleware software support of AXIS Pro Suite and Health Toolkit

# SBC6511 Rugged SOSA Aligned 6U VPX Single Board Computer with 9<sup>th</sup> Gen Intel Xeon E CPU

## Specifications

### Processor

- Xeon E CPU (E-2276ME) formerly known as Coffee Lake Refresh
- 6-cores at 2.8 GHz
- 45W TDP
- CM246 PCH (Platform Controller Hub)
- 12 MB Cache

### SDRAM

- Maximum memory configuration of 64 GB DDR4 SDRAM @ 2400 MHz with ECC

### Onboard NVMe Solid State Drive (SSD)

- Up to 256 GB (64 GB standard)

### OpenVPX Module Profiles

- MOD6-PAY-4F1Q1H4U1T1S1S1TU2U2T1H-12.6.3-2

### USB Ports

- 2x USB 3.1 ports routed to P4

### Expansion Plane

- x16 PCIe, 2 x8 PCIe, or 4 x4 PCIe from a Gen3 capable switch to P2

### Data Plane

- 2x 10/40 Gb KX4/KR4 Ethernet

### Control Plane

- 2x 10/100/1000BASE-T
- 2x 1000BASE-KX/10GBASE-KR

### Management Plane

- IPMI (Baseboard Management Controller) in accordance with VITA 46.11

### Serial Ports

- 2x RS-232 or 1x 422 routed to P4
- 2x RS-232/LVCMOS routed to P1/P5

### Serial ATA

- 4x SATA 3.0 capable (6 Gb/s), routed to P4

### Video Controller

- 1x DisplayPort port routed to P4

### Front I/O (air-cooled only)

- 1x USB 3.0 port
- 1x 10/100/1000BASE-T
- 1x RS-232/422
- 1x DisplayPort

### XMC Expansion Slots

- Both sites (one routed to P5)
  - XMC - x8 PCIe Gen3
- Available with VITA 42 connectors (contact factory for VITA 61 connectors)

### General Purpose I/O

- Up to 10x GPIO, 5V tolerant, each capable of generating an interrupt; routed to P2/P4
- 3x GPIO (LVDS) routed to P1/P2/P5

## Block diagram (SOSA-Aligned)

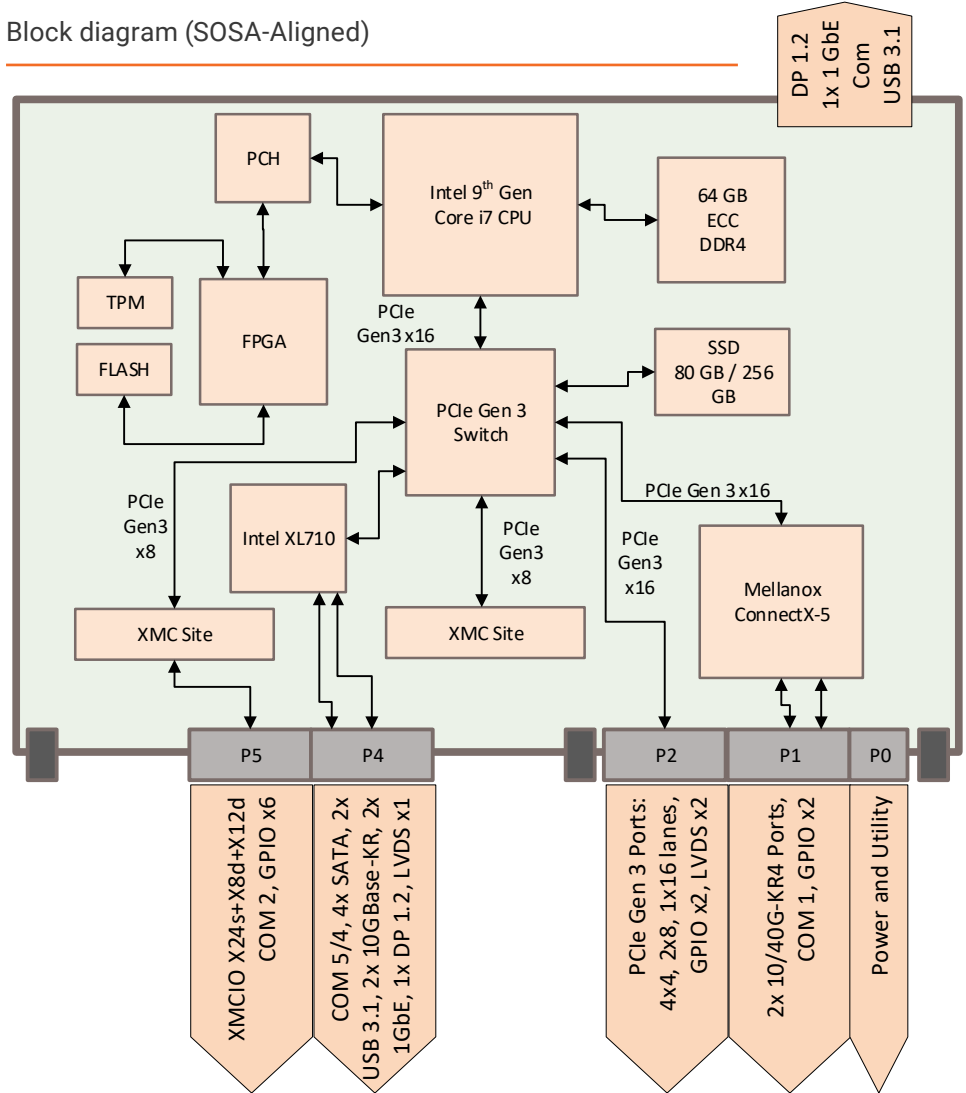

### FPGA

- Xilinx Zynq UltraScale+ FPGA (ZU7EG) with advanced security features
  - Enhanced anti-tamper features
  - Encryption
  - Physically unclonable functions (PUF)
  - Zeroization

### SOSA

- Optional I/O via P3 and P6 (P3 and P6 are optionally loaded)
- Allows for alignment with OpenVPX payload profile: MOD6-PAY-4F1Q1H4U1T1S1S1TU2U2T1H-12.6.3-6

### Other Hardware Features

- Hardware Write Protection

### LED

- 1x power
- 3x status LEDs and 4x BIT status (software control)

### NVRAM / Watchdog / ETI / TPM

- 1 MB non-volatile RAM (FRAM)
- Watchdog timer (software programmable)
- Elapsed Time Indicator
- Temperature Sensors
- TPM 2.0 (Trusted Platform Module)

### Power Requirements

- +12V and 3.3V\_AUX

# SBC6511 Rugged SOSA Aligned 6U VPX Single Board Computer with 9<sup>th</sup> Gen Intel Xeon E CPU

## Specifications

### Processor

- Xeon E CPU (E-2276ME) formerly known as Coffee Lake Refresh
- 6-cores at 2.8 GHz
- 45W TDP
- CM246 PCH (Platform Controller Hub)
- 12 MB Cache

### SDRAM

- Maximum memory configuration of 64 GB DDR4 SDRAM @ 2400 MHz with ECC

### Onboard NVMe Solid State Drive (SSD)

- Up to 256 GB (64 GB standard)

### OpenVPX Module Profiles

- MOD6-PAY-4F1Q2U2T-12.2.1-8
- MOD6-PAY-4F1Q2U2T-12.2.1-15

### USB Ports

- 6x USB 3.0 ports routed to P4/P6

### Expansion Plane

- x16 PCIe, 2 x8 PCIe, or 4 x4 PCIe from a Gen3 capable switch to P2

### Data Plane

- 2x 10/40 Gb KX4/KR4 Ethernet

### Control Plane

- 2x 10/100/1000BASE-T
- 2x 1000BASE-KX/10GBASE-KR

### Management Plane

- IPMI (Baseboard Management Controller) in accordance with VITA 46.11

### Serial Ports

- 2x RS-232 or 1x 422 routed to P4
- 2x RS-232/LVCMOS routed to P1/P5

### Serial ATA

- 4x SATA 3.0 capable (6 Gb/s), routed to P4

### Video Controller

- 1x DisplayPort port routed to P4
- 1x DisplayPort port routed to P6

### Front I/O (air-cooled only)

- 1x USB 3.0 port
- 1x 10/100/1000BASE-T
- 1x RS-232/422
- 1x DisplayPort

### XMC Expansion Slots

- Both sites (one routed to P3, one to P5)
  - XMC - x8 PCIe Gen3
- Available with VITA 42 connectors (contact factory for VITA 61 connectors)

### General Purpose I/O

- Up to 10x GPIO, 5V tolerant, each capable of generating an interrupt; routed to P2/P4
- 3x GPIO (LVDS) routed to P1/P2/P5

## Block diagram (Non-SOSA)

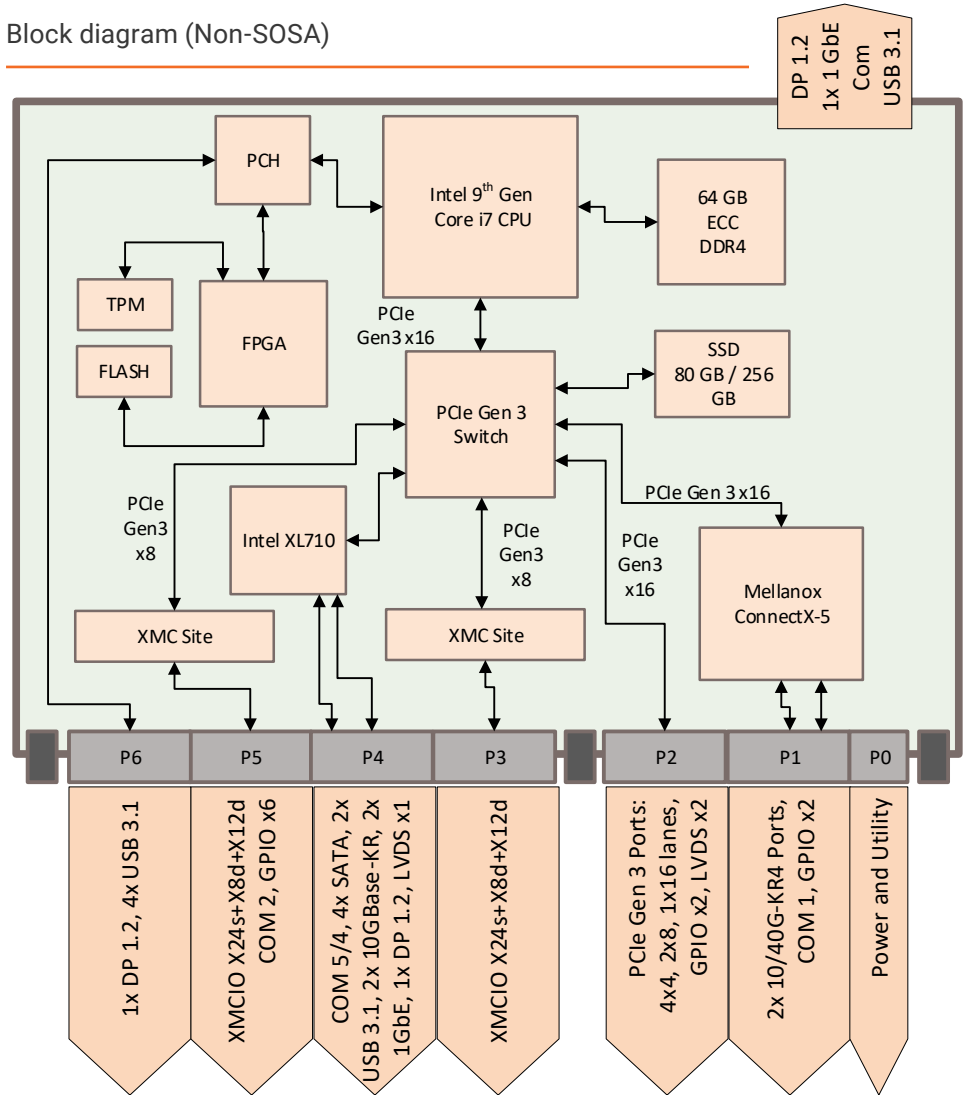

### FPGA

- Xilinx Zynq UltraScale+ FPGA (ZU7EG) with advanced security features
  - Enhanced anti-tamper features
  - Encryption
  - Physically unclonable functions (PUF)
  - Zeroization

### Other Hardware Features

- Hardware Write Protection

### LED

- 1x power
- 3x status LEDs and 4x BIT status (software control)

### NVRAM / Watchdog / ETI / TPM

- 1 MB non-volatile RAM (FRAM)
- Watchdog timer (software programmable)
- Elapsed Time Indicator
- Temperature Sensors
- TPM 2.0 (Trusted Platform Module)

### Power Requirements

- +12V and 3.3V\_AUX

Americas: 866-OK-ABACO or +1-866-652-2226

Europe, Africa, Middle East, & Asia Pacific: +44 (0) 1327-359444

Locate an Abaco Systems Sales Representative visit: [abaco.com/products/sales](http://abaco.com/products/sales)

[abaco.com](http://abaco.com)



©2020 Abaco Systems. All Rights Reserved. Intel and Xeon are registered trademarks, and Core is a trademark, of Intel Corporation. Xilinx and Zynq are registered trademarks, and UltraScale+ is a trademark, of Xilinx, Inc. Windows is a registered trademark of Microsoft Corporation. Linux is the registered trademark of Linus Torvalds. VxWorks is a registered trademark of Wind River Systems. DisplayPort is a trademark of the Video Electronics Standards Association (VESA). PCIe is a trademark of PCI-SIG. All other trademarks are the property of their respective owners. Specifications are subject to change without notice.